

N°	Code	Description	Qty
1	12-00232	FLUE HOOD	1
2	15-00064	COMBUSTION CHAMBER FRONT PANEL	1
3	15-00090	ROOM-SEALED CHAMBER BACK PANEL	1
4	15-00147	FRAME SUPPORT RIGHT SIDE	1
5	15-00148	FRAME SUPPORT LEFT SIDE	1
6	15-00150	ROOM-SEALED CHAMBER TOP	1
7	15-00151	EXPANSION VESSEL TOP BRACKET	1
8	15-00152	CASING LEFT SIDE PANEL	1
9	15-00153	CASING RIGHT SIDE PANEL	1
10	15-00210	COMBUSTION CHAMBER RIGHT SIDEPANEL	1
11	15-00211	COMBUSTION CHAMBER LEFT SIDEPANEL	1
12	15-00264	FLUE HOOD BACK PIECERBS23	1
13	15-00294	EXPANSION VESSEL BOTTOM BRACKET	1
14	15-01800	FAN FIXING PLATE	1
15	15-02136	BOTTOM BOILER PLATE	1
16	15-02163	ROOM-SEALED CHAMBER BOTTOM	1
17	15-02372	CONTROL PANEL LEFT SIDE BRACKET	1
18	15-02373	CONTROL PANEL RIGHT SIDE BRACKET	1
19	30-00011	CERAMIC FIBRE FRONT SIDE	1
20	30-00014	CERAMIC FIBRE BACK SIDE	1
21	30-00025	CERAMIC FIBRE DX/SX	2
22	34542LP	FLUE HOOD LEFT DEFLECTOR	1
23	35-00540	CASING FRONT SIDE PANELRBSNRG R15	1
24	43212LA	RIGHT/LEFT PANEL INSULATION	2
25	43213LA	ALUMINIUM ADHESIVE RIGHT/LEFTSIDE PANEL 300X220	1
26	43283LA	INSULATION FRONT PANEL M24395x520x10sp	1
27	62011LP	HOLES CLOSING PLATE Ø100	2
28	74266LP	CASING WALL HANGING BRACKETM24-RK25/34OV	1
29	74503LP	WALL MOUNTING BRACKETM24	1

Disegnatore	Rev.	data revisione	Autore revisione	Descrizione revisione
crislian.pazzaglini				
Modificato				
crislian.pazzaglini				
Data di creazione	Scala	Materiale	Sp.	Peso (Kg)
24/07/2023	16			18,034
Note				
Descrizione completa				
RSR 24				
- MET - HDIMS13 - R15				



tecnologia nel calore dal 1959

Codice Revisione

A991A212J101 00

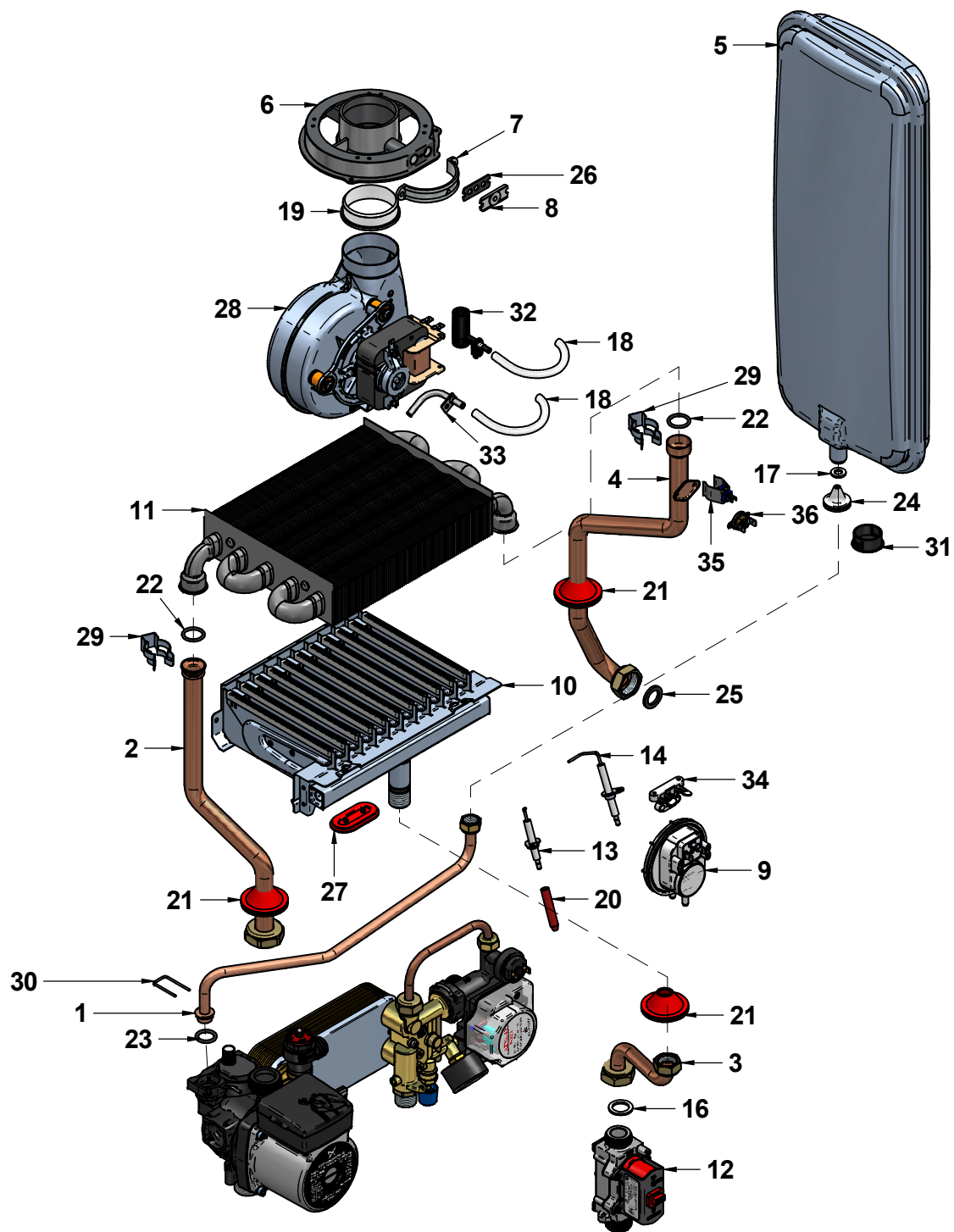

N°	код	наименование	Qty
1	12-00918	трубка Ø10 подключение расширительного бака от насоса	1
2	12-02913	трубка Ø18 отопления подача	1
3	12-02916	трубка Ø14 подключение газового клапана	1
4	12-03317	трубка Ø18 отопления обратка	1
5	25-00283	расширительный бак на 7 литров	1
6	27066LA	ревизия дымохода	1
7	27067LA	крепежный зажим	1
8	27068LA	ПЛАСТИНА ДЛЯ ЗАКРЫТИЯ ДЫМОХОДА ДЛЯ ОСМОТРА	1
9	30-00023	маностат 2.14-1.96	1
10	30-00052	горелка	1
11	30-00084	теплообменник	1
12	30-00346	газовый клапан SGV C1100010	1
13	35007LA	электрод розжига E. 0774527	1
14	35009LA	электрод ионизации EL.0774929	1
15	40-00616	КАБЕЛЬ НАГРЕВ. ЭЛЕМЕНТА РЕЛЕ ДАВЛЕНИЯ ВОЗДУХА	1
16	43001LA	прокладка Ø 23.5x17x2 3/4" -AFM34	1
17	43003LA	прокладка Ø15x8x2 3/8" -AFM34	1
18	43018LA	силиконовая трубка Ø8x4	2
19	43031LA	уплотнитель вентилятора D.54	1
20	43040LA	КРАСНЫЙ РЕЗИНОВЫМ КОЛПАЧОК	1
21	43047LA	УПЛОТНИТЕЛЬ	3
22	43118LA	ПРОКЛАДКА	2
23	43150LA	ПРОКЛАДКА 14X30	1
24	43154LA	БЕЛАЯ КОНИЧЕСКАЯ ШАЙБА HTG FLOW	1
25	43159LA	ПРОКЛАДКА 16x24x2,5 3/4"	1
26	43220LA	ПРОВЕРКА ДЫМОХОДА РЕЗИНОВОЙ ШАЙБОЙ EPDM	1
27	43352LA	СИЛИКОНОВАЯ КРАСНАЯ ШАЙБА FB12/1-ОВАЛЬНАЯ	1
28	50-00011	ВЕНТИЛЯТОР	1
29	54020LA	ЗАЖИМ ДЛЯ КРЕПЛЕНИЯ ТЕПЛООБМЕННИКА	2
30	55-00227	СКОБА КРЕПЛЕНИЯ	1
31	55-00237	КРЫШКА D.28 ДЛЯ РАСШИРИТЕЛЬНОГО БАЧКА	1
32	57525LA	ТРУБКА ВЕНТУРИ	1
33	57526LP	ТОЧКА ДАВЛЕНИЯ MINI 24 FIME	1
34	59023LA	ПЛАСТИКОВЫЙ ЗАЖИМ	1
35	73516LA	ДАТЧИК ТЕМПЕРАТУРЫ-T7335D1123B	1
36	86006LA	ПРЕДОХРАНИТЕЛЬНЫЙ ТЕРМОСТАТ 95 C	1

Disegnatore	Rev.	data revisione	Autore revisione	Descrizione revisione
cristian.pazzaglini				
Modificato				
cristian.pazzaglini				
Data di creazione	Scala	Materiale	Sp.	Peso (Kg)
24/07/2023	14,5			18,034
Note				
Descrizione completa RSR 24 - MET - HDIMS13 - R15				



tecnologia nel calore dal 1959

Codice Revisione
A991A212J101 00

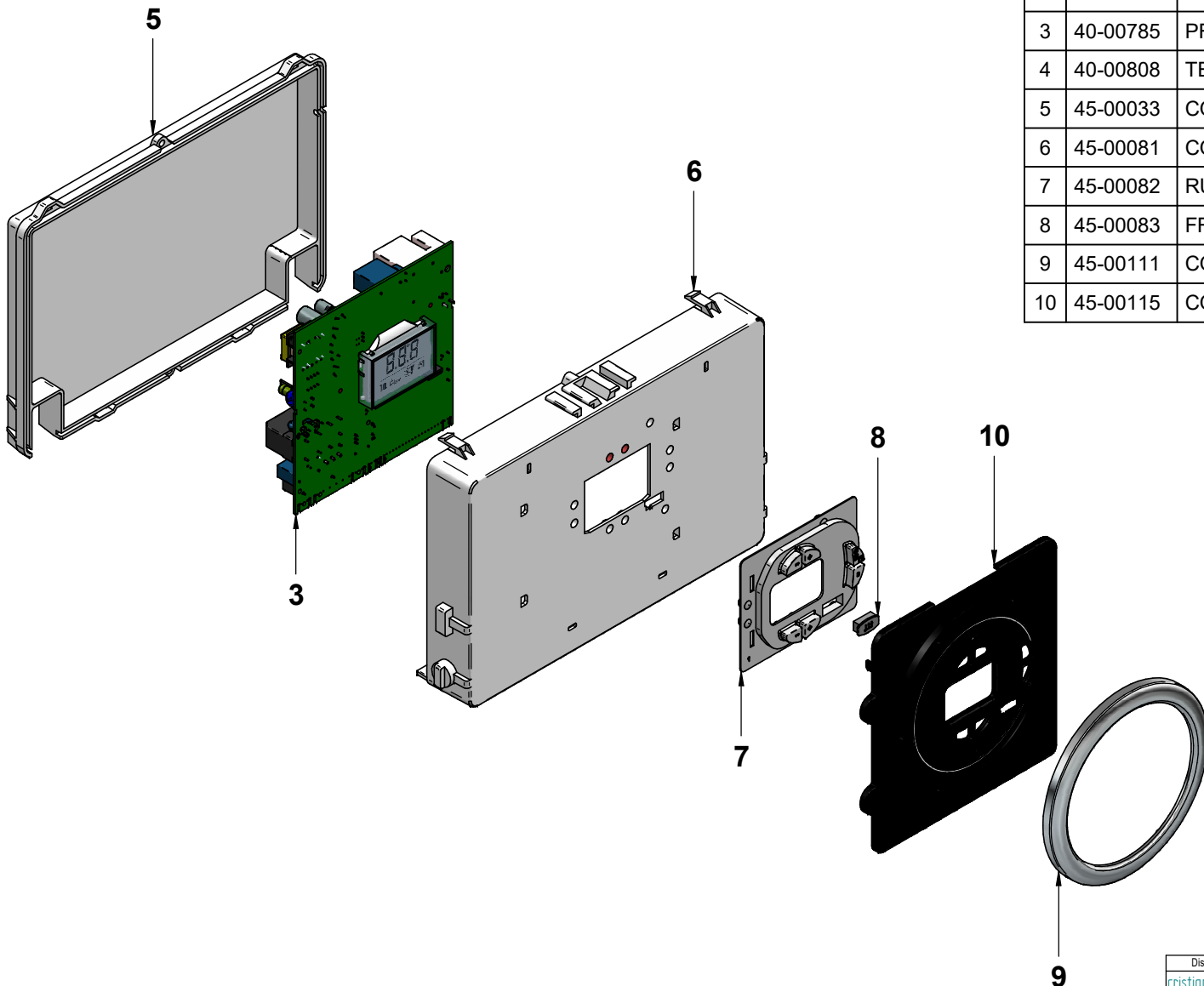

N°	Code	Description	Qty
1	40-00444	DIVERTER VALVE CABLE	1
2	40-00784	LOW VOLTAGE DEVICES/ AIR PRESSURE SWITCH CABLE	1
3	40-00785	PRINTED CIRCUIT BOARD RSR - R9 - HDIMS13	1
4	40-00808	TERMINAL BLOCK / CIRCULATING PUMP / FAN CABLE	1
5	45-00033	CONTROL PANEL BACK PLATE	1
6	45-00081	CONTROL PANEL R9	1
7	45-00082	RUBBER BOTTON	1
8	45-00083	FRONT CONNECTOR RUBBER BOTTON	1
9	45-00111	CONTROL PANEL CHROME-PLATED FRAME	1
10	45-00115	CONTROL PANEL FRONT COVER	1

Disegnatore	Rev.	data revisione	Autore revisione	Descrizione revisione
cristian.pazzaglini				
Modificato				
cristian.pazzaglini				
Data di creazione	Scala	Materiale	Sp.	Peso (Kg)
24/07/2023	125			,380
Note				
Descrizione completa CONTROL PANEL COMPLETE RSR 24 - R15 - NO B3 - NERO - CINA				



tecnologia nel calore dal 1959

Codice	Revisione
41-00538	00