

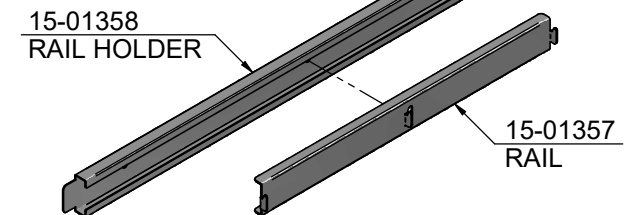

N°	Code	Description	Qty
1	12-01716	FRAME	1
2	15-00996	IGNITION TRANSFORMER MOUNTING PLATE	2
3	15-01043	CONTROL PANEL LEFT SIDE BRACKET	1
4	15-01044	CONTROL PANEL RIGHT SIDE BRACKET	1
5	15-01078	CASING RIGHT SIDE PANEL	1
6	15-01079	CASING LEFT SIDE PANEL	1
7	15-01250	BURNER SUPPORT BRACKET	2
8	15-01337	WALL FIXING BRACKET	1
9	15-01348	ROOM-SEALED CHAMBER BOTTOM PLATE	1
10	15-01349	ROOM-SEALED CHAMBER TOP	1
11	15-01353	ROOM-SEALED CH.TOP REINFORCING BRACKET	2
12	15-01354	SPACER	1
13	15-01363	SLAVE CONTROL PANEL LEFT SIDE BRACKET	1
14	15-01364	SLAVE CONTROL PANEL RIGHT SIDE BRACKET	1
15	15-01461	CONDENSATE TRAP SUPPORT BRACKET	2
16	15-01462	ROOM-SEALED CH.TOP REINFORCING LEFT SIDE	1
17	35-00091	INSULATION CASING SIDE PANELS	2
18	35-00128	CASING FRONT PANEL	1
19	35-00143	INSULATION FRONT PANEL	1
20	35-00145	INSULATION TOP PANEL	1
21	35-00146	LEFT MANIFOLD INSULATION	1
22	35-00147	RIGHT MANIFOLD INSULATION	1
23	35-00148	GAS MANIFOLD INSULATION	1
24	43288LA	ALUMINIUM ADHESIVE FRONT PANEL 420x370	1

**12-01733
RAILING KIT
to be supplied
in case of cascades**



Disegnatore	Rev.	data revisione	Autore revisione	Descrizione revisione
cristian.pazzagliani				
Modificato				
cristian.pazzagliani				
Data di creazione	Scala	Materiale	Sp.	Peso (Kg)
09/05/2023	16.5			84,583
Note				
Descrizione completa R1K 100 - MET - ERP - SKM1.2 - MIAH4.12 - R2 - GPA				
 tecnologia nel calore dal 1959				Codice A991A182DA01
				Revisione 00

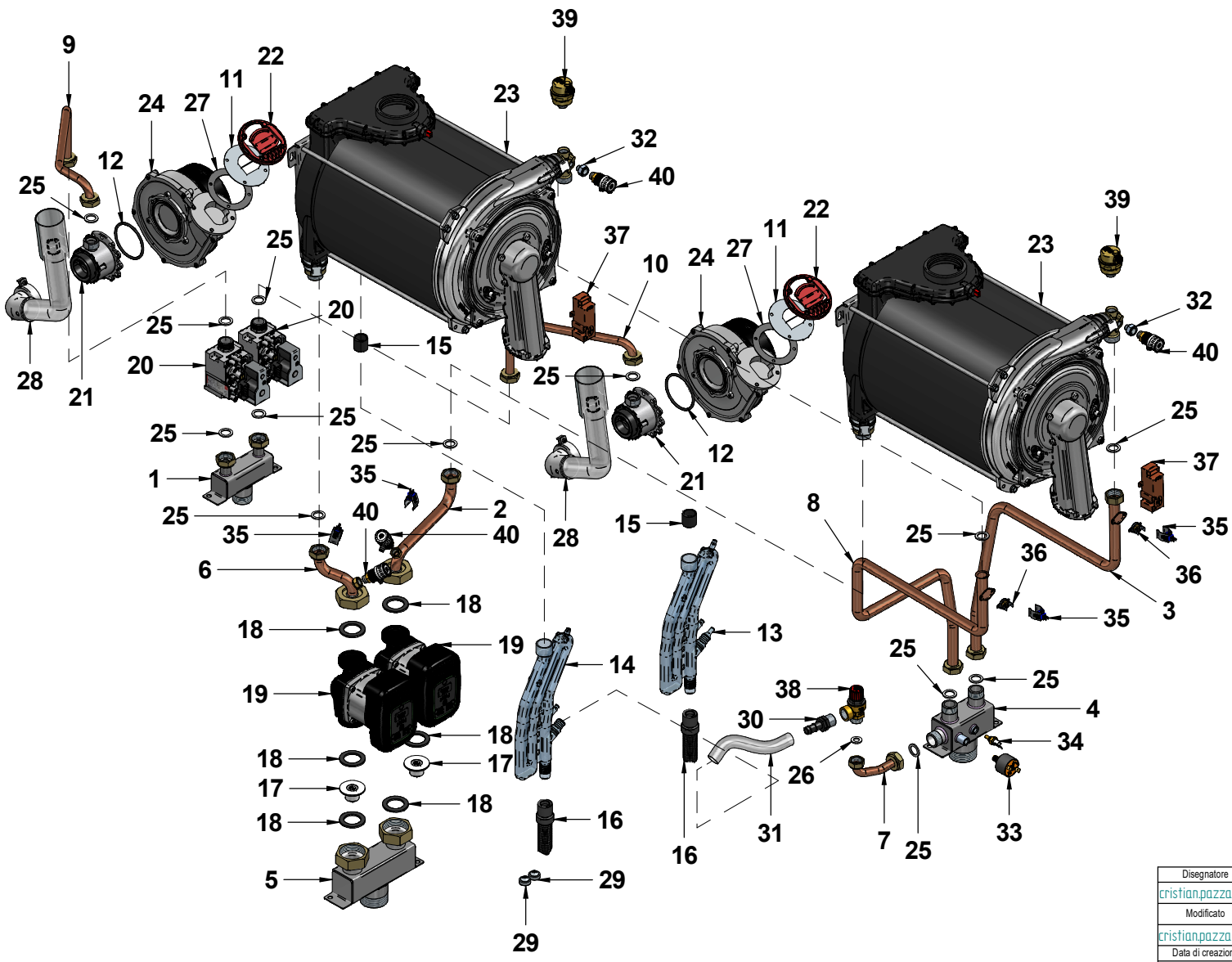

N°	Code	Description	Qty
1	12-01715	GAS VALVES MANIFOLD	1
2	12-01727	PIPE Ø18 - HEAT EXCHANGER 2	1
3	12-01731	PIPE Ø18 HTG FLOW - HEAT EXCHANGER 2	1
4	12-01865	HEATING FLOW MANIFOLD	1
5	12-01866	HEATING RETURN MANIFOLD	1
6	12-01873	PIPE Ø18 - HEAT EXCHANGER LEFT SIDE	1
7	12-01905	PIPE Ø14 SAFETY VALVE	1
8	12-01961	PIPE Ø18 EXCHANGER 1 HTG FLOW	1
9	12-02203	PIPE Ø14 GAS VALVE	1
10	12-02204	PIPE Ø14 GAS VALVE	1
11	15-01624	BURNER FLANGE 34+50 KW SK.3	2
12	25-00386	O-RING 62,00x3 VENTURI	2
13	25-00520	CONDENSATE TRAP/SIPHON IN PP - CLOSED	1
14	25-00525	CONDENSATE TRAP/SIPHON IN PP	1
15	25-00526	CONDENSATE DRAIN TERMINAL	2
16	25-00527	CONDENSATE DRAIN PIPE	2
17	25-00530	NON-RETURN VALVE 1"1/2	2
18	25-00531	WASHER 1"1/2 EPDM	6
19	25-01111	CIRCULATING PUMP GPA25-11H	2
20	30-00134	GAS VALVE - SIT 848 SIGMA	2
21	30-00214	VENTURI NAT.GAS	2
22	30-00286	FLANGE WASHER WITH CLAPET	2
23	30-00334	RADIANT EXCHANGER SK1.2 50 MONOTHERMIC	2
24	40-00244	EXHAUST FAN RG128/1300	2
25	43001LA	WASHER Ø 23.5x17x2 3/4" -AFM34	13
26	43002LA	WASHER Ø 18.5x10.2x2 1/2" -AFM34	1
27	43278LA	FLANGE WASHER D.82 EPDM	2
28	50-00397	AIR INTAKE PIPE - LEFT MOUNTING	2
29	55-00313	METRIC SNAP-FIT GROMMETS	2
30	55-00355	RUBBER.HOLDER 1/2"x16	1
31	55-00356	ANTIFREEZE PIPE Ø14x19R2K - 0133050183800	1
32	56048LA	ADAPTER 2520 1/8-1/4	2
33	59015LA	WATER PRESSURE SWITCH PC5411	1
34	73507LA	WHITE SENSOR 1/8"	1
35	73516LA	HTG CLIP SENSOR X PIPE 17/18mm	4
36	86006LA	SAFETY THERMOSTAT 95gr(ø)E.	2
37	88023LA	IGN.TRANSFORMER AC 230VAC50-60HZ	2
38	96005LA	SAFETY VALVE 1/2" 3 bar	1
39	96012LA	AUTOMATIC AIR VENT VALVE 3/8"	2
40	96055LA	AIR VENT VALVE 1/4 METAL	4

Disegnatore	Rev.	data revisione	Autore revisione	Descrizione revisione
crislian.pazzagliani				
Modificato				
crislian.pazzagliani				
Data di creazione	Scala	Materiale	Sp.	Peso (Kg)
09/05/2023	1/7,5			84,583
Note				
Descrizione completa R1K 100 - MET - ERP - SKM12 - MIAH412 - R2 - GPA				



tecnologia nel calore dal 1959

Codice Revisione
A991A182DA01 00

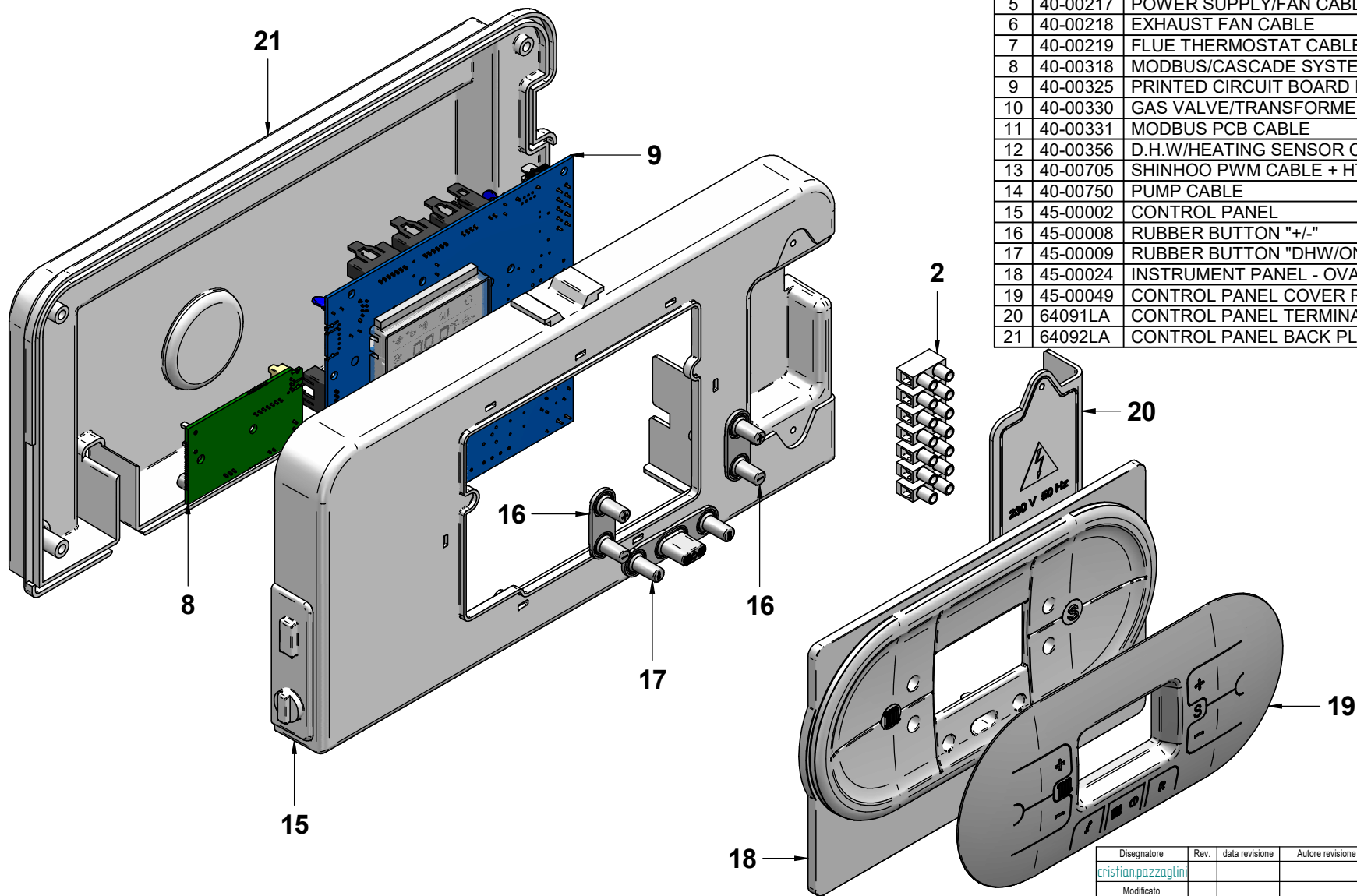

N°	Code	Description	Qty
1	40-00097	WATER PRESSURE SWITCH CABLE	1
2	40-00103	POWER SUPPLY CABLE	1
3	40-00107	FRAME-PRINTED CIRCUIT BOARD CABLE	1
4	40-00215	SAFETY THERMOSTAT CABLE	1
5	40-00217	POWER SUPPLY/FAN CABLE	1
6	40-00218	EXHAUST FAN CABLE	1
7	40-00219	FLUE THERMOSTAT CABLE	1
8	40-00318	MODBUS/CASCADE SYSTEMS INTERFACE PCB	1
9	40-00325	PRINTED CIRCUIT BOARD R2 PANEL	1
10	40-00330	GAS VALVE/TRANSFORMER CABLE - MASTER/SLAVE UNITS	1
11	40-00331	MODBUS PCB CABLE	1
12	40-00356	D.H.W/HEATING SENSOR CABLE	1
13	40-00705	SHINHO PWM CABLE + HTG RETURN SENSOR	1
14	40-00750	PUMP CABLE	1
15	45-00002	CONTROL PANEL	1
16	45-00008	RUBBER BUTTON "+/-"	2
17	45-00009	RUBBER BUTTON "DHW/ON/HTG"	1
18	45-00024	INSTRUMENT PANEL - OVAL	1
19	45-00049	CONTROL PANEL COVER R1K GRAY	1
20	64091LA	CONTROL PANEL TERMINAL BLOCK COVER	1
21	64092LA	CONTROL PANEL BACK PLATE	1

Disegnatore	Rev.	data revisione	Autore revisione	Descrizione revisione
crislian.pazzaglino				
Modificato				
crislian.pazzaglino				
Data di creazione	Scala	Materiale	Sp.	Peso (Kg)
09/05/2023	1:1			,607
Note				
Descrizione completa CONTROL PANEL COMPLETE MASTER R1K 100 - GPA				



tecnologia nel calore dal 1959

Codice **41-00505** Revisione **00**

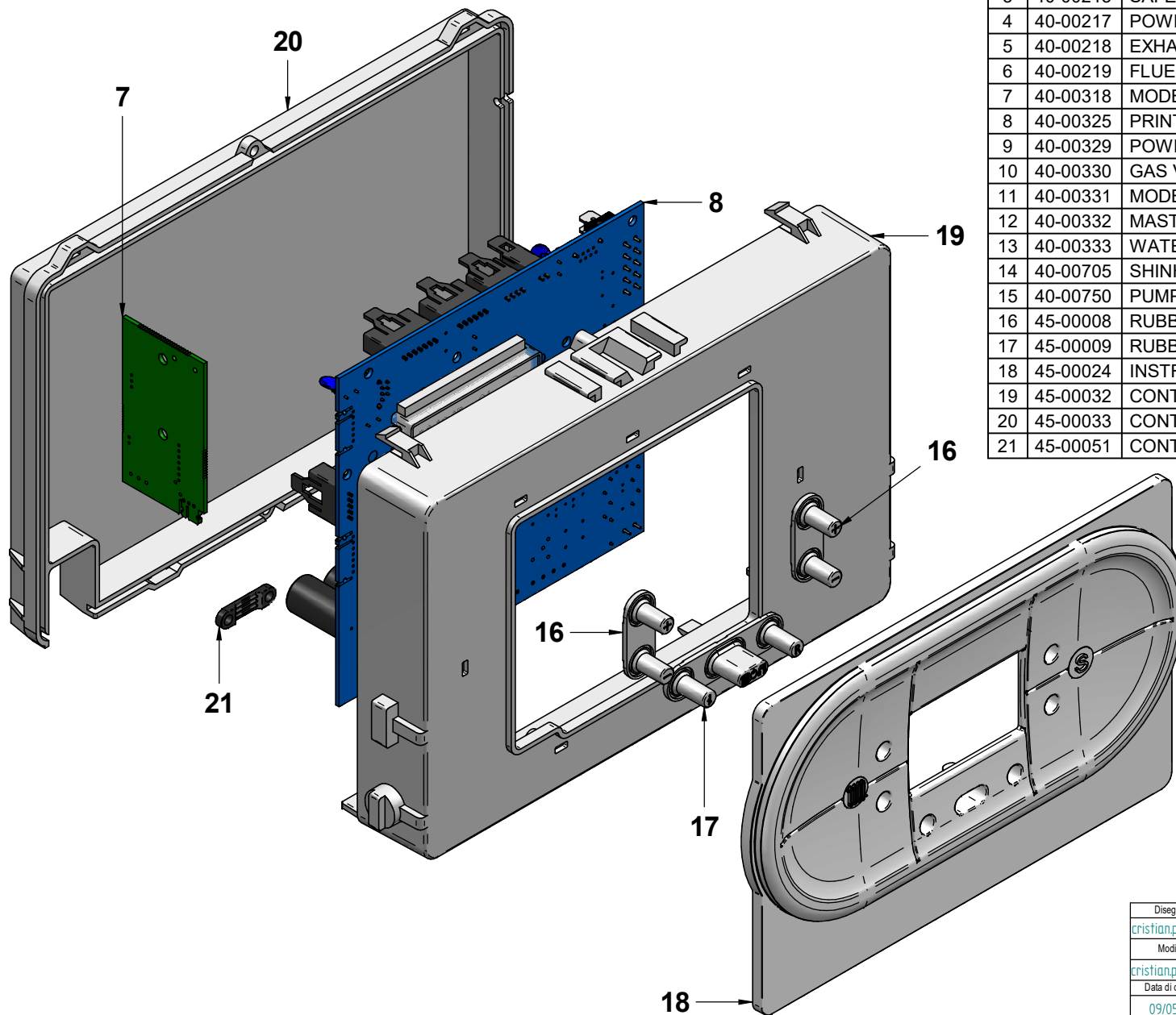

N°	Code	Description	Qty
1	31352LA	D.H.W SENSOR CABLE	1
2	40-00107	FRAME-PRINTED CIRCUIT BOARD CABLE	1
3	40-00215	SAFETY THERMOSTAT CABLE	1
4	40-00217	POWER SUPPLY/FAN CABLE	1
5	40-00218	EXHAUST FAN CABLE	1
6	40-00219	FLUE THERMOSTAT CABLE	1
7	40-00318	MODBUS/CASCADE SYSTEMS INTERFACE PCB	1
8	40-00325	PRINTED CIRCUIT BOARD R2 PANEL	1
9	40-00329	POWER SUPPLY CABLE SLAVE PCB	1
10	40-00330	GAS VALVE/TRANSFORMER CABLE - MASTER/SLAVE UNITS	1
11	40-00331	MODBUS PCB CABLE	1
12	40-00332	MASTER/SLAVE PCBs CONNECTING CABLE	1
13	40-00333	WATER PRESSURE SWITCH/SLAVE PCB LINK JUMPER CABLE	1
14	40-00705	SHINHOO PWM CABLE + HTG RETURN SENSOR	1
15	40-00750	PUMP CABLE	1
16	45-00008	RUBBER BUTTON "+/-"	2
17	45-00009	RUBBER BUTTON "DHW/ON/HTG"	1
18	45-00024	INSTRUMENT PANEL - OVAL	1
19	45-00032	CONTROL PANEL FRONTAL COVER R5	1
20	45-00033	CONTROL PANEL BACK PLATE	1
21	45-00051	CONTROL PANEL TERMINAL FIXING CLAMP - R5	1

Disegnatore	Rev.	data revisione	Autore revisione	Descrizione revisione
cristian.pazzaglini				
Modificato				
cristian.pazzaglini				
Data di creazione	Scala	Materiale	Sp.	Peso (Kg)
09/05/2023	1:15			398.524
Note				
Descrizione completa CONTROL PANEL COMPLETE SLAVE R1K 100 - GPA				
				Revisione
tecnologia nel calore dal 1959				00
Codice				00
41-00506				00

N°	Code	Description	Qty
1	13-00355	COND. EXCHANGER WITHOUT DOOR - SINGLE PIPE - R1K 50	1
2	13-00376	BURNER DOOR - COND.EXCHANG. R1K 50 SK1.2	1
3	25-00312	O-RING - BURNER DOOR	1
4	30-00104	CERAMIC FIBRE - COND. EXCHANGER - C0084TR021	1
5	30-00131	CERAMIC AIRBED - COND. EXCHANGER	1
6	30-00325	CERAMIC FIBRE-ROUND TYPE 30SP.	1
7	35026LA	ELECTRODE WASHER	2
8	40-00127	IGNITION ELECTRODE W/CABLE	1
9	40-00128	IONISATION ELECTRODE W/CABLE	1
10	55-00137	WASHER 74x61 sp.17 EPDM	1
11	73517LA	THERMO FUSE 102øC RED ISTMQ 1/4" 4X45 - TSD2921	1

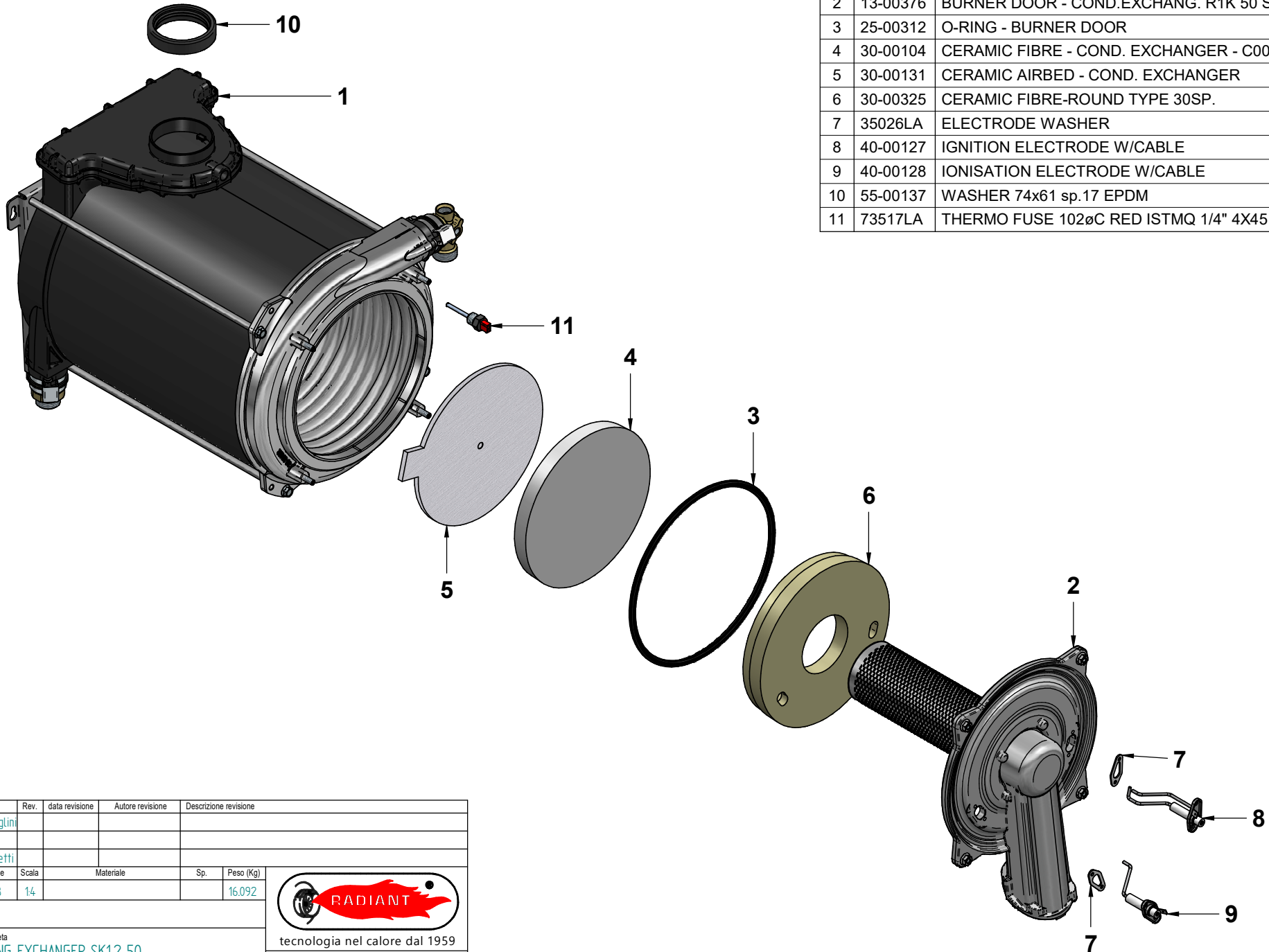

Disegnatore	Rev.	data revisione	Autore revisione	Descrizione revisione
cristian.pazzaglini				
Modificato				
francesco.bonetti				
Data di creazione	Scala	Materiale	Sp.	Peso (Kg)
07/03/2018	14			16.092
Note				
Descrizione completa CONDENSING EXCHANGER SK1.2 50				
 tecnologia nel calore dal 1959				
Codice			Revisione	
30-00334			00	

OGNI ELEMENTO PUEBBLI NUN CUOMI PPRUPRIETARIE. LA DOTTI DI FISSAZIONE E DOTTI DI CANTERAZIONE IMPAZIONE SONTU I SONTU DI PRELAVAZIONE DI DOTTI SONTU RESPONSABILI PER QUANTITAZIONE NEARTEZZE. CONTINUTE NEL PRESENTE SPECIFICAZIONE SE DOTTI DI STAMPAZIONE. TUTTI I DOTTI SONTU RESERVATI. NESSUNA PARTE DI QUESTI DOCUMENTI PUO' ESSERE RIPRODOTTA, FOTOCOPIATA, FOTOGRAFATA, O ALTRIMENTI RIVELATA SENZA IL CONSENSO SCRITTO DI RADIANT. IL PRESENTE DOCUMENTO E' UN DOCUMENTO TECNICO. IL PRESENTE DOCUMENTO E' UN DOCUMENTO TECNICO. IL PRESENTE DOCUMENTO E' UN DOCUMENTO TECNICO.